

Wooden Cook Top

GET READY!

Do you want to "get cooking" with your new cooktop? Sure you do! Here's how to OPEN it when you want to play and how to CLOSE it when you want to take the fun on the road!

GET SET!**To Open Your Cooktop:**

1: Place the cooktop with the front facing you. Turn the knobs counterclockwise to loosen them.

2: Pull the handle to slide the back out of the base.

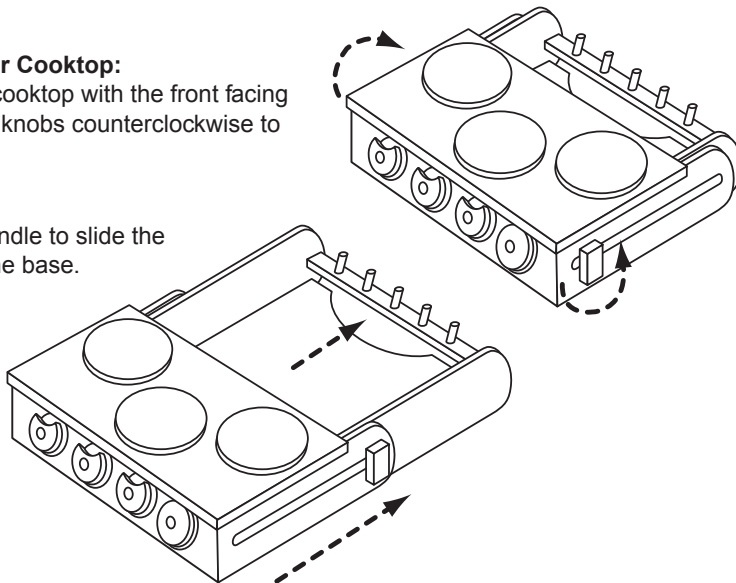

3: Swing the back up and, holding the back in place. Turn the knobs clockwise to tighten them.

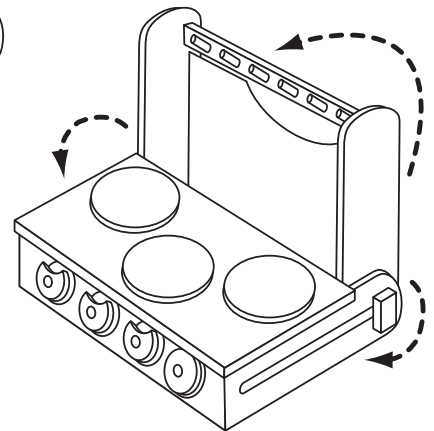

Now you're cooking! Are you a plain-and-simple cook in a diner? Or a fancy chef in an expensive restaurant? Or maybe you just want to whip up something at home for your friends? You can play-act lots of scenes with your cooktop! The only ingredients you need are your imagination and your cooktop! The stove knobs and the clock hands move to add to the fun. And you can hang your own cooking accessories on the pegged bar!

To Close Your Cooktop:

1. Place the cooktop with the front facing you. Turn the right knobs counterclockwise to loosen them. Hold onto the back so that it doesn't fall.

2. Lower the back so that it's lying flat. Slide it into the cooktop base.

3. Turn the knobs clockwise to tighten them.

☐ Now you're ready to stir up some fun anywhere you go! Use the pegged bar as a handle for easy carrying!

GO!

You're finished! Now you know how to open and close your cooktop so that you can have hours and hours of pretend cooking fun!

